

Disassembly Instructions - Variable Speed Pencil Grinder, 60K MAX.

Models: 52850, 52855

Important: Use these instructions along with tool parts page or manual.

Notice: Shut off air supply. Open **51665** ON/OFF Valve to deplete air.

- Disconnect tool from air supply hose.
- Use **95731**, 8 mm Wrench and **51694** Pin Wrench to remove accessory from collet.
- Remove **51657** Collet Cap and insert. **Notice:** If needed, use **96486** Collet Insert Removal Tool.

Disassembly:



1. Insert **51694** Pin Wrench through housing and spindle.
 - Fasten housing in vise with aluminum or bronze jaws, with hose end pointing up.
 - Pull up on **55407** Spring clamp to release overhose.
 - Use a 15 mm or adjustable wrench to loosen **55405** Valve Lock.
Turn counterclockwise.

Visit Our Website: www.dynabrade.com

Email: customer.service@dynabrade.com

DYNABRADE, INC. • DYNABRADE INTERNATIONAL
8989 Sheridan Drive, Clarence, New York 14031-1490 USA
Telephone: (716) 631-0100 • Fax: 716-631-2073 • Int'l Fax: 716-631-2524

DYNABRADE DO BRASIL
Rua Oneda, 632, Sao Bernardo do Campo • SP – CEP 09895-280
Telephone: 55-11-4390-0133 • Fax: 55-11-4399-1067

DYNABRADE EUROPE S.à.r.l.
Zone Artisanale, L-5485 Wormeldange—Haut, Luxembourg
Telephone: +352 768 494 1 • Fax: +352 768 495

DYNABRADE INDIA ABRASIVE POWER TOOLS Pvt Ltd.
EL-54, TTC Industrial Area, M.I.D.C. Mahape, Electronic Zone, Navi Mumbai - 400705
Maharashtra, India • Telephone: +91 22 2763 2226 • Fax: +91 22 2763 2228

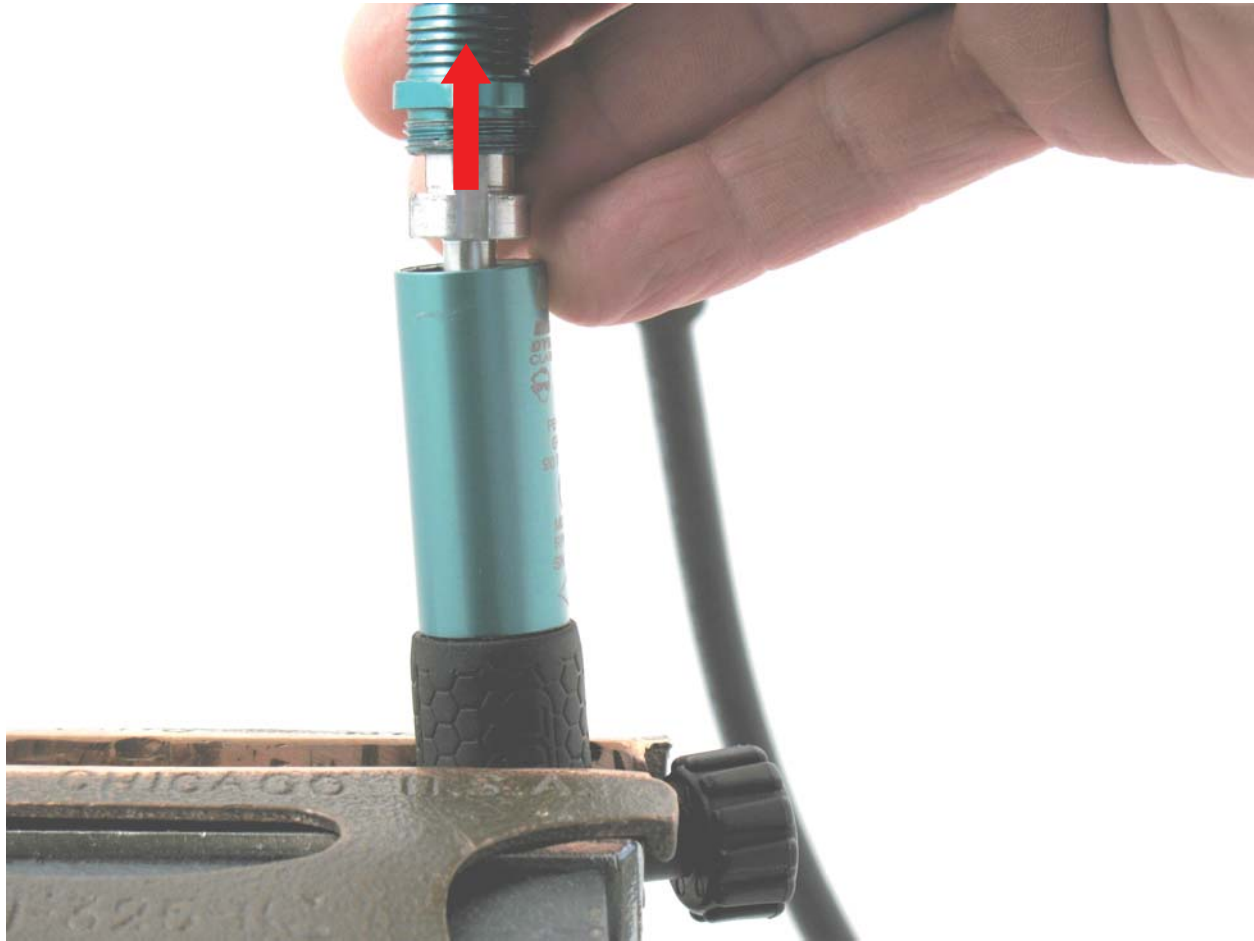

2. Remove **55419** Manifold Stem and hoses.

- **NOTICE:** Push-Lock style air hose & fittings are used on this tool. To remove, cut hose as shown in photos: **A** & **B**.

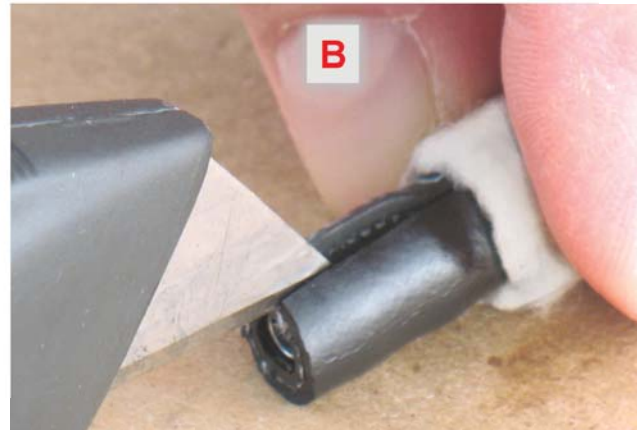

Visit Our Website: www.dynabrade.com

Email: customer.service@dynabrade.com

DYNABRADE, INC. • DYNABRADE INTERNATIONAL
8989 Sheridan Drive, Clarence, New York 14031-1490 USA
Telephone: (716) 631-0100 • Fax: 716-631-2073 • Int'l Fax: 716-631-2524

DYNABRADE DO BRASIL
Rua Oneda, 632, Sao Bernardo do Campo • SP – CEP 09895-280
Telephone: 55-11-4390-0133 • Fax: 55-11-4399-1067

DYNABRADE EUROPE S.à.r.l.
Zone Artisanale, L-5485 Wormeldange—Haut, Luxembourg
Telephone: +352 768 494 1 • Fax: +352 768 495

DYNABRADE INDIA ABRASIVE POWER TOOLS Pvt Ltd.
EL-54, TTC Industrial Area, M.I.D.C. Mahape, Electronic Zone, Navi Mumbai - 400705
Maharashtra, India • Telephone: +91 22 2763 2226 • Fax: +91 22 2763 2228



3. Use a pick to remove **55418** Muffler. **NOTICE:** Inset Photo.
 - Carefully remove housing from vise, and invert to remove **55402** Valve Seat, **55401** Rear Plate, **55400** Cylinder and **55404** Vanes.

Visit Our Website: www.dynabrade.com

Email: customer.service@dynabrade.com

DYNABRADE, INC. • DYNABRADE INTERNATIONAL
8989 Sheridan Drive, Clarence, New York 14031-1490 USA
Telephone: (716) 631-0100 • Fax: 716-631-2073 • Int'l Fax: 716-631-2524

DYNABRADE DO BRASIL
Rua Oneda, 632, Sao Bernardo do Campo • SP – CEP 09895-280
Telephone: 55-11-4390-0133 • Fax: 55-11-4399-1067

DYNABRADE EUROPE S.à.r.l.
Zone Artisanale, L-5485 Wormeldange—Haut, Luxembourg
Telephone: +352 768 494 1 • Fax: +352 768 495

DYNABRADE INDIA ABRASIVE POWER TOOLS Pvt Ltd.
EL-54, TTC Industrial Area, M.I.D.C. Mahape, Electronic Zone, Navi Mumbai - 400705
Maharashtra, India • Telephone: +91 22 2763 2226 • Fax: +91 22 2763 2228

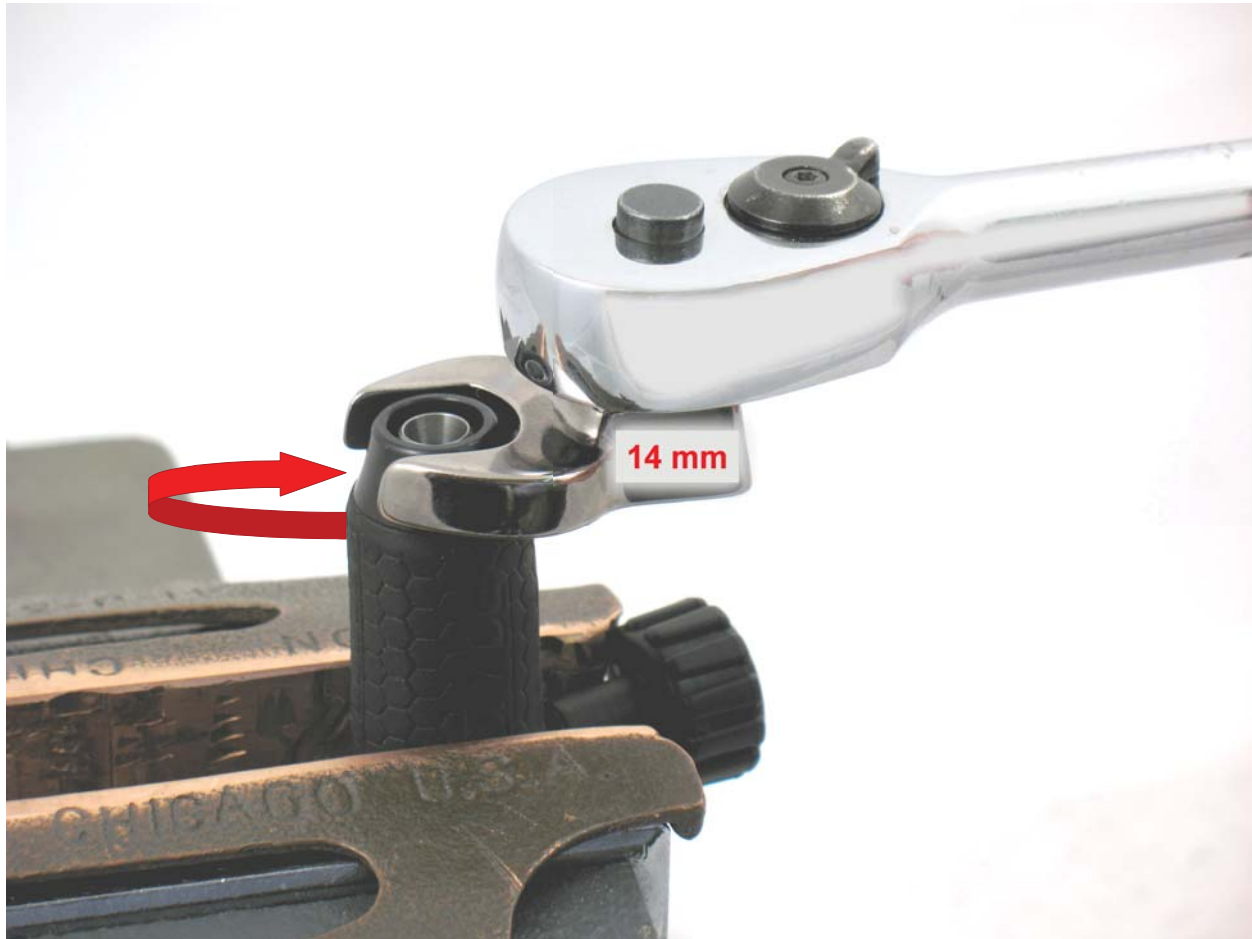

4. Fasten housing in vise with **55390** Collet Guard pointing up.
 - Use a 14 mm or adjustable wrench to remove **55390** Collet Guard.
Turn counterclockwise.

Visit Our Website: www.dynabrade.com

Email: customer.service@dynabrade.com

DYNABRADE, INC. • DYNABRADE INTERNATIONAL
8989 Sheridan Drive, Clarence, New York 14031-1490 USA
Telephone: (716) 631-0100 • Fax: 716-631-2073 • Int'l Fax: 716-631-2524

DYNABRADE DO BRASIL
Rua Oneda, 632, Sao Bernardo do Campo • SP – CEP 09895-280
Telephone: 55-11-4390-0133 • Fax: 55-11-4399-1067

DYNABRADE EUROPE S.à.r.l.
Zone Artisanale, L-5485 Wormeldange—Haut, Luxembourg
Telephone: +352 768 494 1 • Fax: +352 768 495

DYNABRADE INDIA ABRASIVE POWER TOOLS Pvt Ltd.
EL-54, TTC Industrial Area, M.I.D.C. Mahape, Electronic Zone, Navi Mumbai - 400705
Maharashtra, India • Telephone: +91 22 2763 2226 • Fax: +91 22 2763 2228



5. Use **96479** Retainer Wrench to remove **51548** Bearing Retainer.
Turn counterclockwise.
 - Remove **94984** Debris Eliminator.



6. Remove **51694** Pin Wrench.
 - Use a soft-faced hammer to bump **55392** Spindle and remove it from housing.

Visit Our Website: www.dynabrade.com

Email: customer.service@dynabrade.com

DYNABRADE, INC. • DYNABRADE INTERNATIONAL
8989 Sheridan Drive, Clarence, New York 14031-1490 USA
Telephone: (716) 631-0100 • Fax: 716-631-2073 • Int'l Fax: 716-631-2524

DYNABRADE DO BRASIL
Rua Oneda, 632, Sao Bernardo do Campo • SP – CEP 09895-280
Telephone: 55-11-4390-0133 • Fax: 55-11-4399-1067

DYNABRADE EUROPE S.à.r.l.
Zone Artisanale, L-5485 Wormeldange—Haut, Luxembourg
Telephone: +352 768 494 1 • Fax: +352 768 495

DYNABRADE INDIA ABRASIVE POWER TOOLS Pvt Ltd.
EL-54, TTC Industrial Area, M.I.D.C. Mahape, Electronic Zone, Navi Mumbai - 400705
Maharashtra, India • Telephone: +91 22 2763 2226 • Fax: +91 22 2763 2228



7. Use **95890** Taper Pin, or a 9 mm (~.354") diameter rod, as a ram, to remove **51544** Bearing, **55416** Spacer and **55394** Wave Spring.

Visit Our Website: www.dynabrade.com

Email: customer.service@dynabrade.com

DYNABRADE, INC. • DYNABRADE INTERNATIONAL
8989 Sheridan Drive, Clarence, New York 14031-1490 USA
Telephone: (716) 631-0100 • Fax: 716-631-2073 • Int'l Fax: 716-631-2524

DYNABRADE DO BRASIL
Rua Oneda, 632, Sao Bernardo do Campo • SP – CEP 09895-280
Telephone: 55-11-4390-0133 • Fax: 55-11-4399-1067

DYNABRADE EUROPE S.à.r.l.
Zone Artisanale, L-5485 Wormeldange—Haut, Luxembourg
Telephone: +352 768 494 1 • Fax: +352 768 495

DYNABRADE INDIA ABRASIVE POWER TOOLS Pvt Ltd.
EL-54, TTC Industrial Area, M.I.D.C. Mahape, Electronic Zone, Navi Mumbai - 400705
Maharashtra, India • Telephone: +91 22 2763 2226 • Fax: +91 22 2763 2228

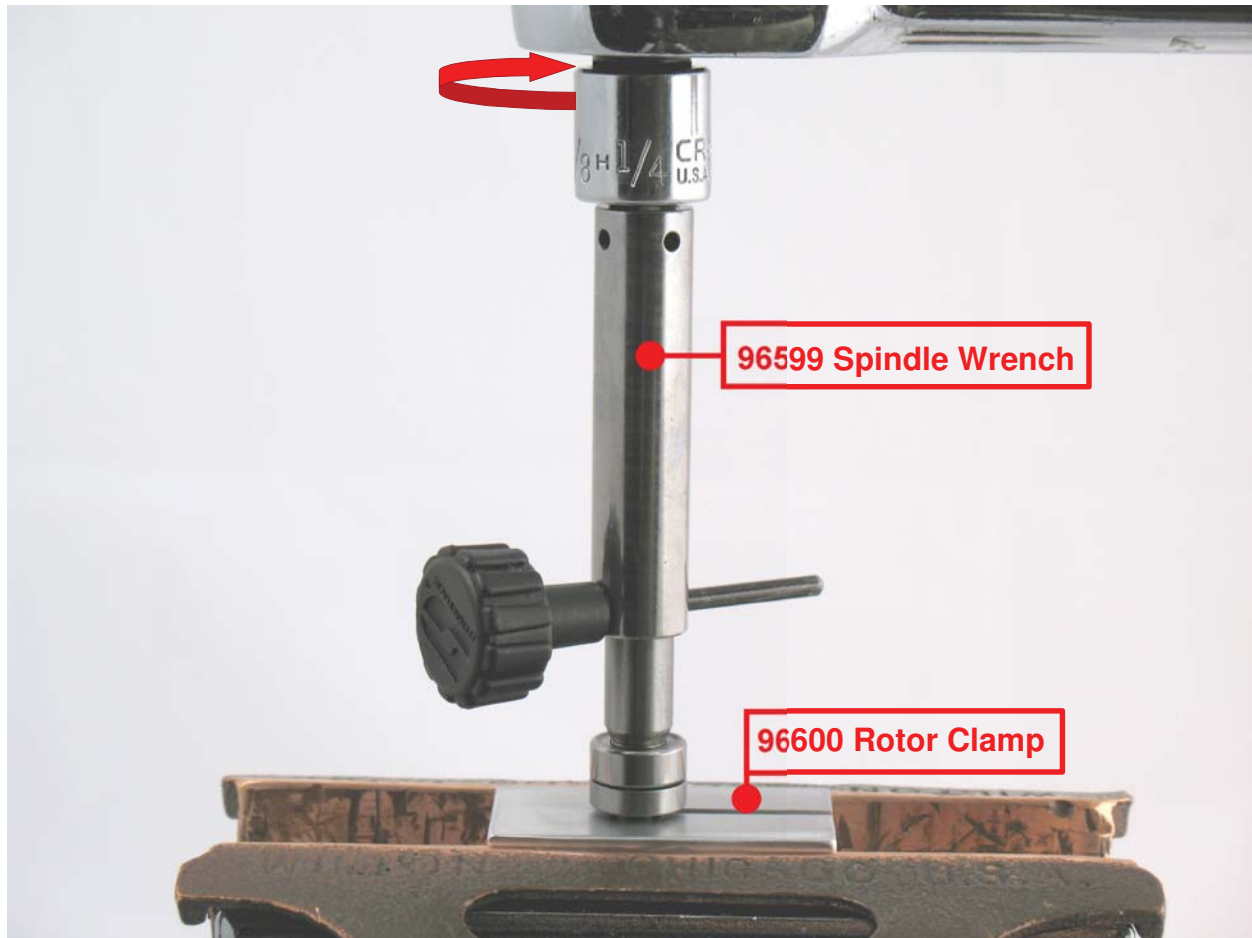

8. Hold **55398** Rotor in **96600** Rotor Clamp and fasten clamp in vise with **55392** Spindle pointing up.
 - Use **96599** Spindle Wrench to remove spindle. Turn counterclockwise.

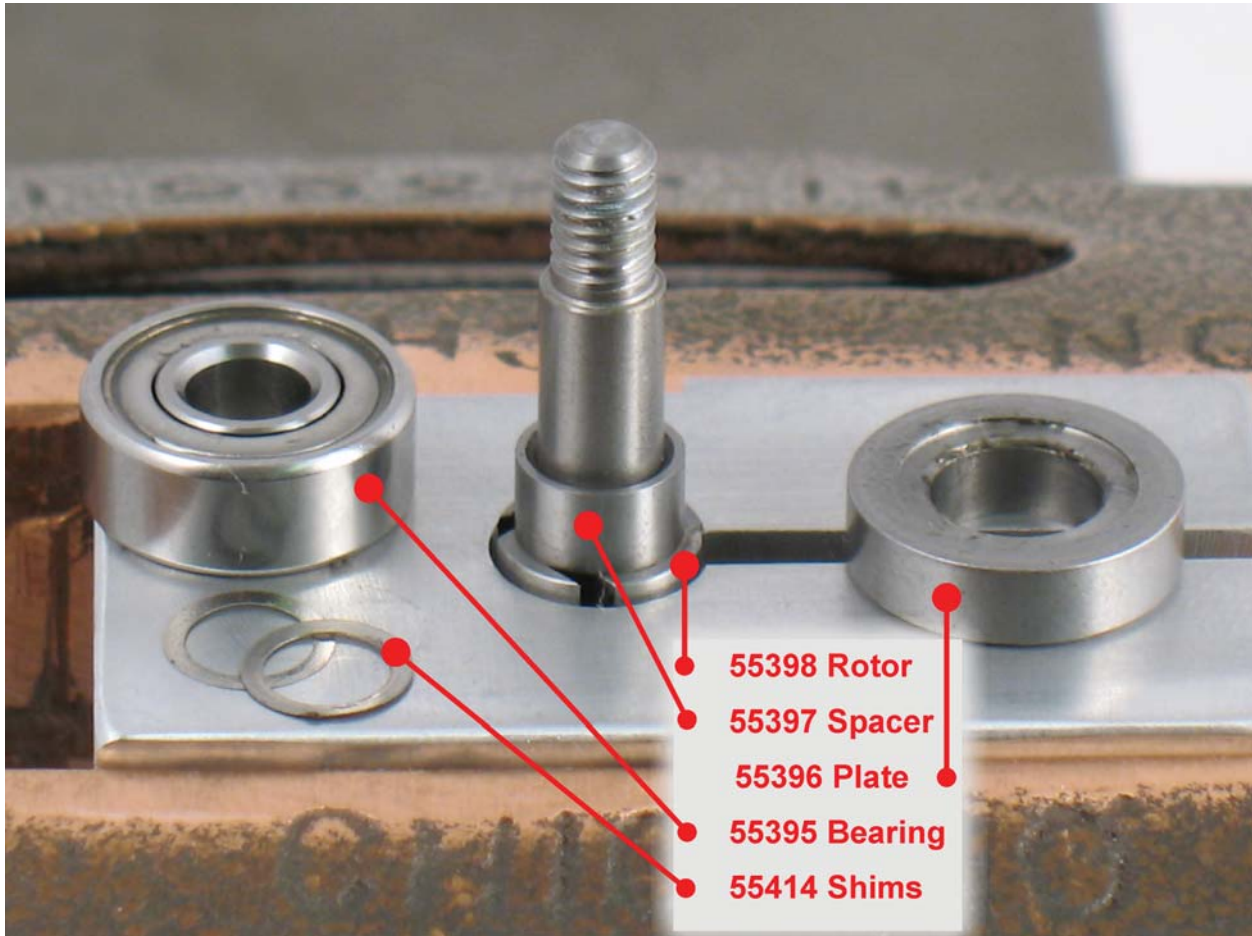

9. Remove **55395** Bearing, **55414** Shims, **55396** Front Bearing Plate & **55397** Spacer.

Visit Our Website: www.dynabrade.com

Email: customer.service@dynabrade.com

DYNABRADE, INC. • DYNABRADE INTERNATIONAL
8989 Sheridan Drive, Clarence, New York 14031-1490 USA
Telephone: (716) 631-0100 • Fax: 716-631-2073 • Int'l Fax: 716-631-2524

DYNABRADE EUROPE S.à.r.l.
Zone Artisanale, L-5485 Wormeldange—Haut, Luxembourg
Telephone: +352 768 494 1 • Fax: +352 768 495

DYNABRADE DO BRASIL
Rua Oneda, 632, Sao Bernardo do Campo • SP – CEP 09895-280
Telephone: 55-11-4390-0133 • Fax: 55-11-4399-1067

DYNABRADE INDIA ABRASIVE POWER TOOLS Pvt Ltd.
EL-54, TTC Industrial Area, M.I.D.C. Mahape, Electronic Zone, Navi Mumbai - 400705
Maharashtra, India • Telephone: +91 22 2763 2226 • Fax: +91 22 2763 2228

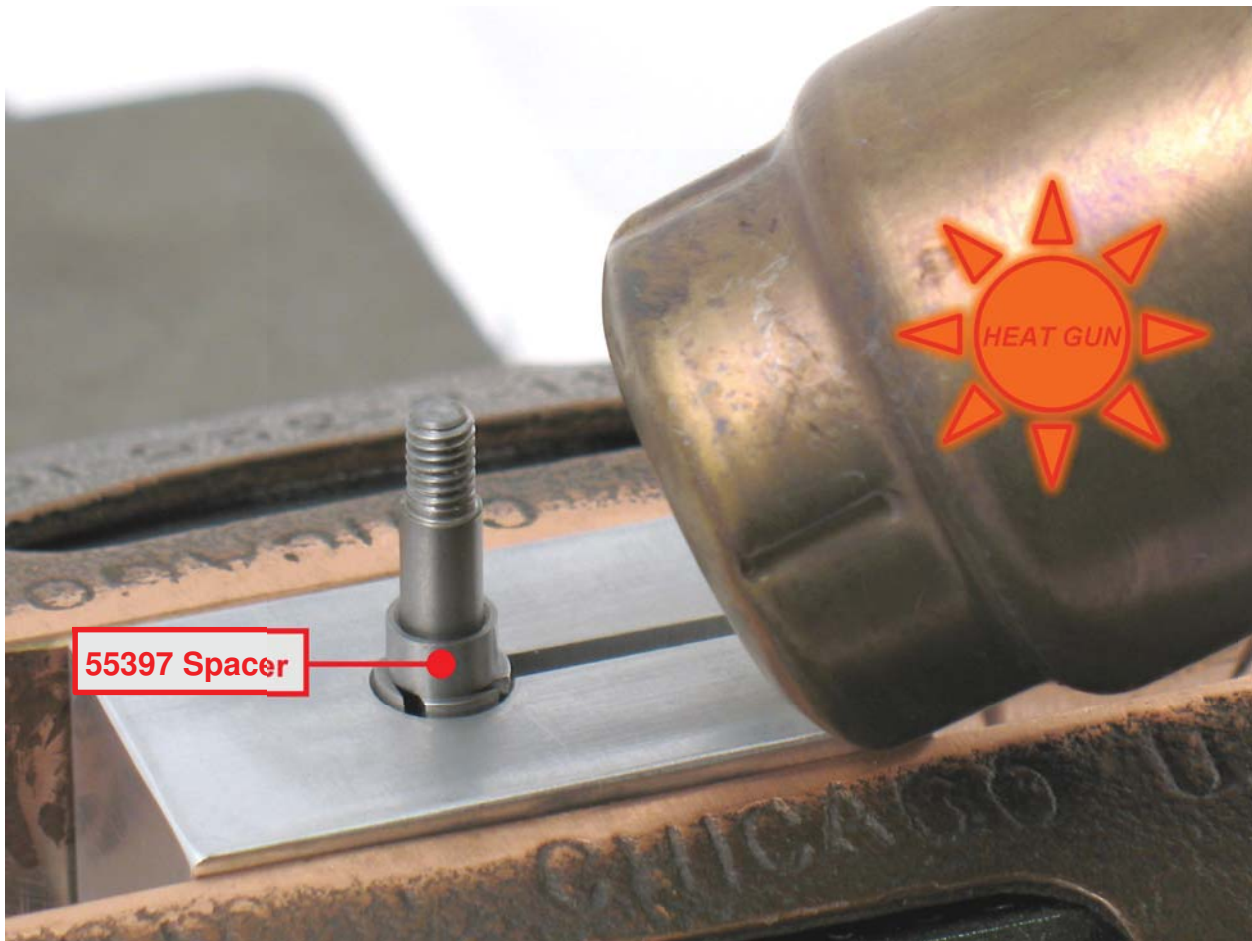

- 10 a. Notice:** If **55397** Spacer is difficult to remove from rotor, use a **HEAT GUN** to warm and expand spacer.

Visit Our Website: www.dynabrade.com

Email: customer.service@dynabrade.com

DYNABRADE, INC. • DYNABRADE INTERNATIONAL
8989 Sheridan Drive, Clarence, New York 14031-1490 USA
Telephone: (716) 631-0100 • Fax: 716-631-2073 • Int'l Fax: 716-631-2524

DYNABRADE DO BRASIL
Rua Oneda, 632, Sao Bernardo do Campo • SP – CEP 09895-280
Telephone: 55-11-4390-0133 • Fax: 55-11-4399-1067

DYNABRADE EUROPE S.à.r.l.
Zone Artisanale, L-5485 Wormeldange—Haut, Luxembourg
Telephone: +352 768 494 1 • Fax: +352 768 495

DYNABRADE INDIA ABRASIVE POWER TOOLS Pvt Ltd.
EL-54, TTC Industrial Area, M.I.D.C. Mahape, Electronic Zone, Navi Mumbai - 400705
Maharashtra, India • Telephone: +91 22 2763 2226 • Fax: +91 22 2763 2228

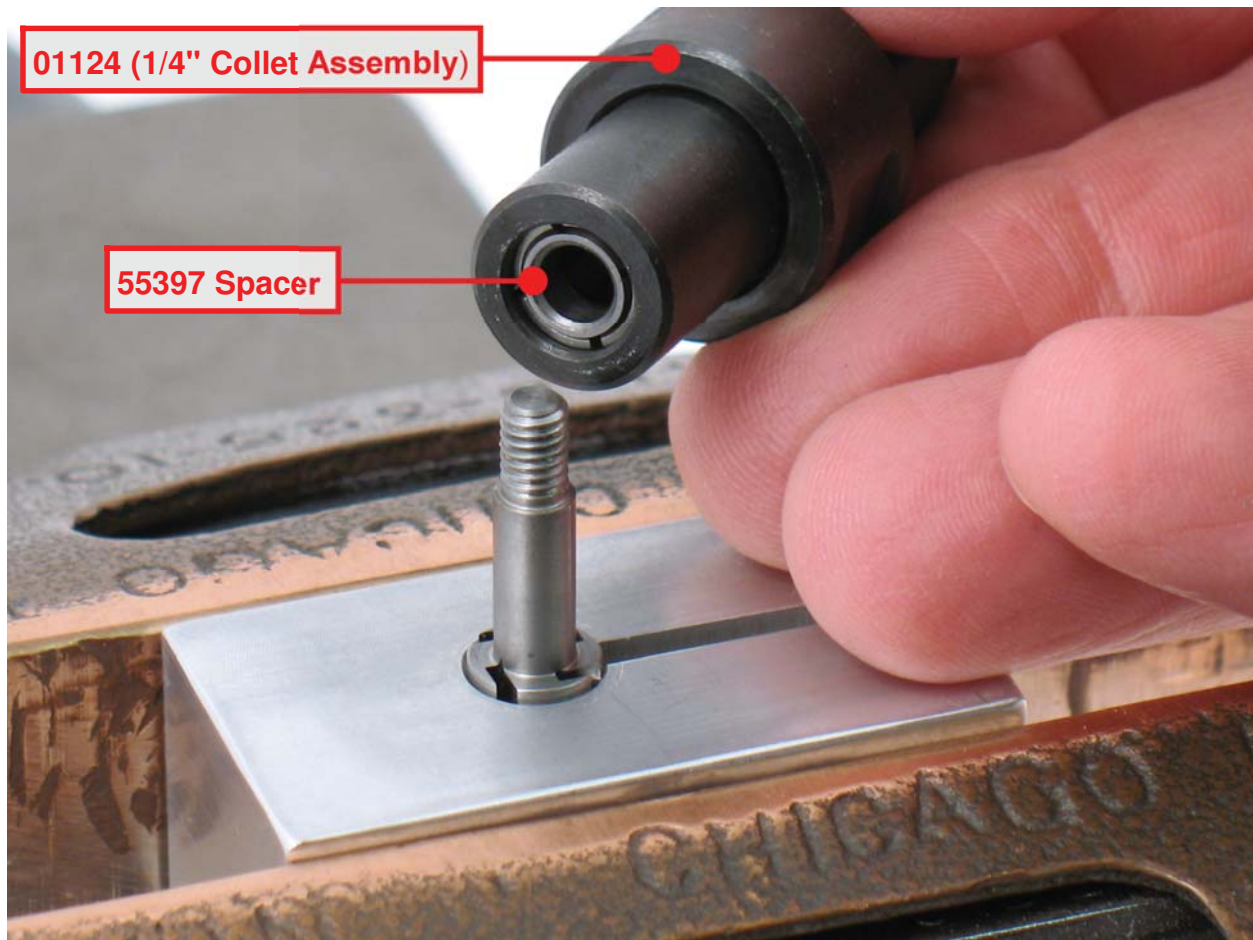

10 b. Use a 1/4" collet assembly (01124 shown in photo) to grab spacer and remove it without damage.

Use tool parts page or manual to identify valve parts and order of disassembly.

Disassembly completed.

Clean, inspect, and replace worn parts before assembling.

Visit Our Website: www.dynabrade.com

Email: customer.service@dynabrade.com

DYNABRADE, INC. • DYNABRADE INTERNATIONAL
8989 Sheridan Drive, Clarence, New York 14031-1490 USA
Telephone: (716) 631-0100 • Fax: 716-631-2073 • Int'l Fax: 716-631-2524

DYNABRADE EUROPE S.à.r.l.
Zone Artisanale, L-5485 Wormeldange—Haut, Luxembourg
Telephone: +352 768 494 1 • Fax: +352 768 495

DYNABRADE DO BRASIL
Rua Oneda, 632, Sao Bernardo do Campo • SP – CEP 09895-280
Telephone: 55-11-4390-0133 • Fax: 55-11-4399-1067

DYNABRADE INDIA ABRASIVE POWER TOOLS Pvt Ltd.
EL-54, TTC Industrial Area, M.I.D.C. Mahape, Electronic Zone, Navi Mumbai - 400705
Maharashtra, India • Telephone: +91 22 2763 2226 • Fax: +91 22 2763 2228



Disassembly/Assembly Instructions

Assembly Instructions - Variable Speed Pencil Grinder, 60K MAX.

Important: Use these instructions along with tool parts page or manual.

Assembly:

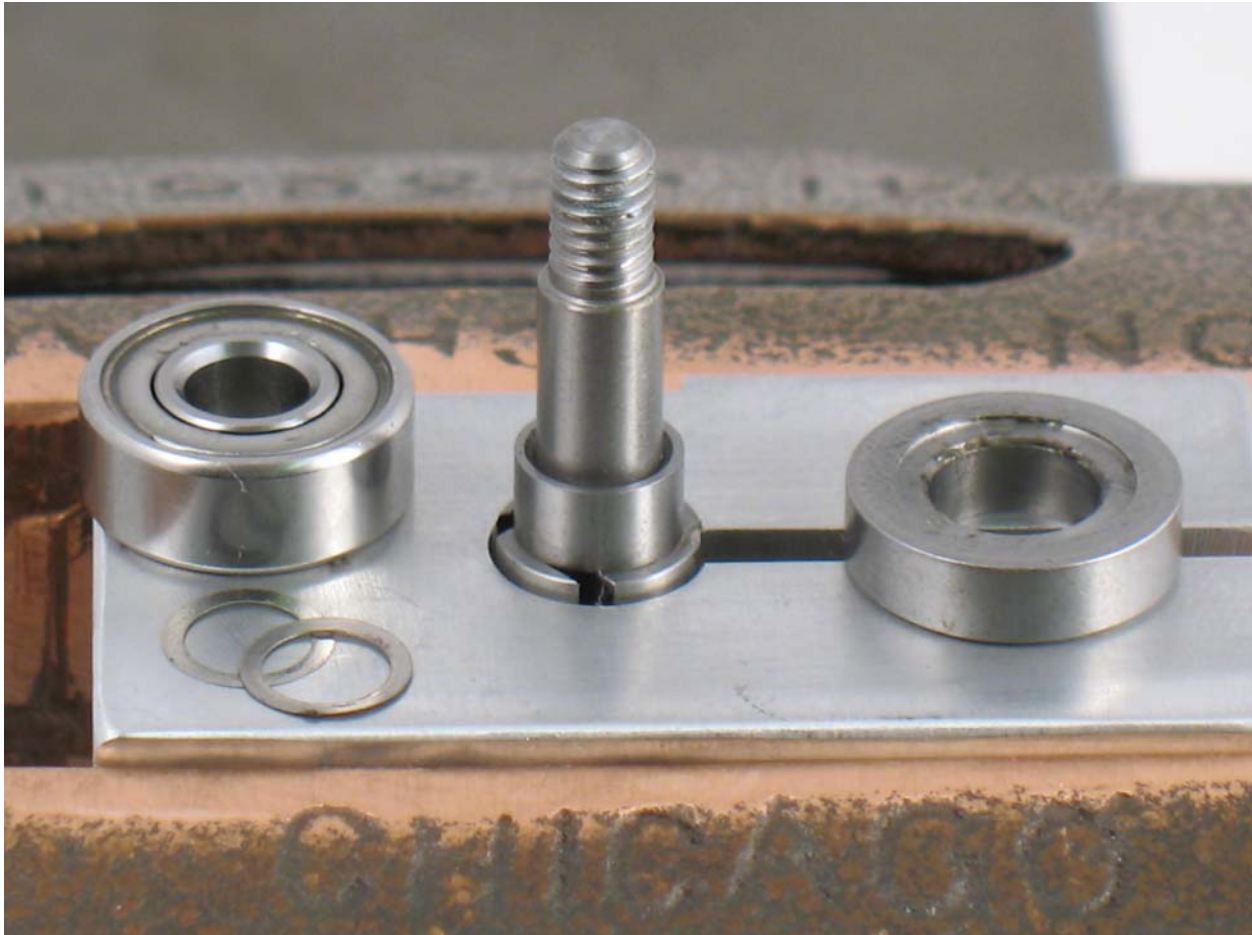

1. Install **55397** Spacer and **55396** Front Bearing Plate onto rotor.
 - Install same thickness shims, or use new .002" (0.05 mm) shim from **55414** Shim Pack.
 - Install **55395** Bearing onto rotor.

Visit Our Website: www.dynabrade.com

Email: customer.service@dynabrade.com

DYNABRADE, INC. • DYNABRADE INTERNATIONAL
8989 Sheridan Drive, Clarence, New York 14031-1490 USA
Telephone: (716) 631-0100 • Fax: 716-631-2073 • Int'l Fax: 716-631-2524

DYNABRADE DO BRASIL
Rua Oneda, 632, Sao Bernardo do Campo • SP – CEP 09895-280
Telephone: 55-11-4390-0133 • Fax: 55-11-4399-1067

DYNABRADE EUROPE S.à.r.l.
Zone Artisanale, L-5485 Wormeldange—Haut, Luxembourg
Telephone: +352 768 494 1 • Fax: +352 768 495

DYNABRADE INDIA ABRASIVE POWER TOOLS Pvt Ltd.
EL-54, TTC Industrial Area, M.I.D.C. Mahape, Electronic Zone, Navi Mumbai - 400705
Maharashtra, India • Telephone: +91 22 2763 2226 • Fax: +91 22 2763 2228

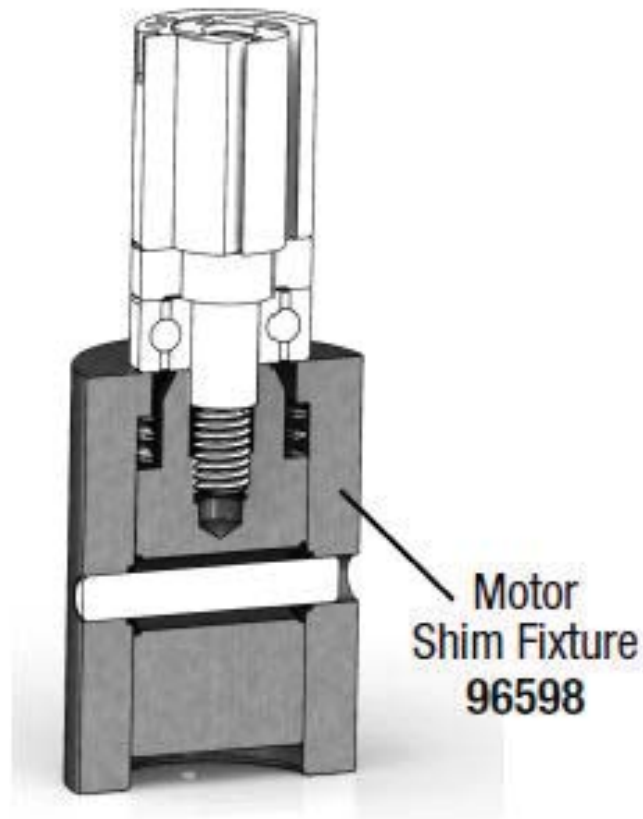

2. Use **96598** Motor Shim Fixture.

- Thread rotor into Motor Shim Fixture, *finger tight*.
- Install **55400** Cylinder over rotor.
- Use depth micrometer to measure distance between surface of cylinder and surface of rotor.



2. **Notice:** Rotor should sit .0015" to .0025" (~0.04 - 0.06 mm) below cylinder.
- If distance needs adjustment, repeat steps, add or remove shims as required.
 - Remove cylinder and loosen assembly from Motor Shim Fixture.

Visit Our Website: www.dynabrade.com

Email: customer.service@dynabrade.com

DYNABRADE, INC. • DYNABRADE INTERNATIONAL
8989 Sheridan Drive, Clarence, New York 14031-1490 USA
Telephone: (716) 631-0100 • Fax: 716-631-2073 • Int'l Fax: 716-631-2524

DYNABRADE DO BRASIL
Rua Oneda, 632, Sao Bernardo do Campo • SP – CEP 09895-280
Telephone: 55-11-4390-0133 • Fax: 55-11-4399-1067

DYNABRADE EUROPE S.à.r.l.
Zone Artisanale, L-5485 Wormeldange—Haut, Luxembourg
Telephone: +352 768 494 1 • Fax: +352 768 495

DYNABRADE INDIA ABRASIVE POWER TOOLS Pvt Ltd.
EL-54, TTC Industrial Area, M.I.D.C. Mahape, Electronic Zone, Navi Mumbai - 400705
Maharashtra, India • Telephone: +91 22 2763 2226 • Fax: +91 22 2763 2228

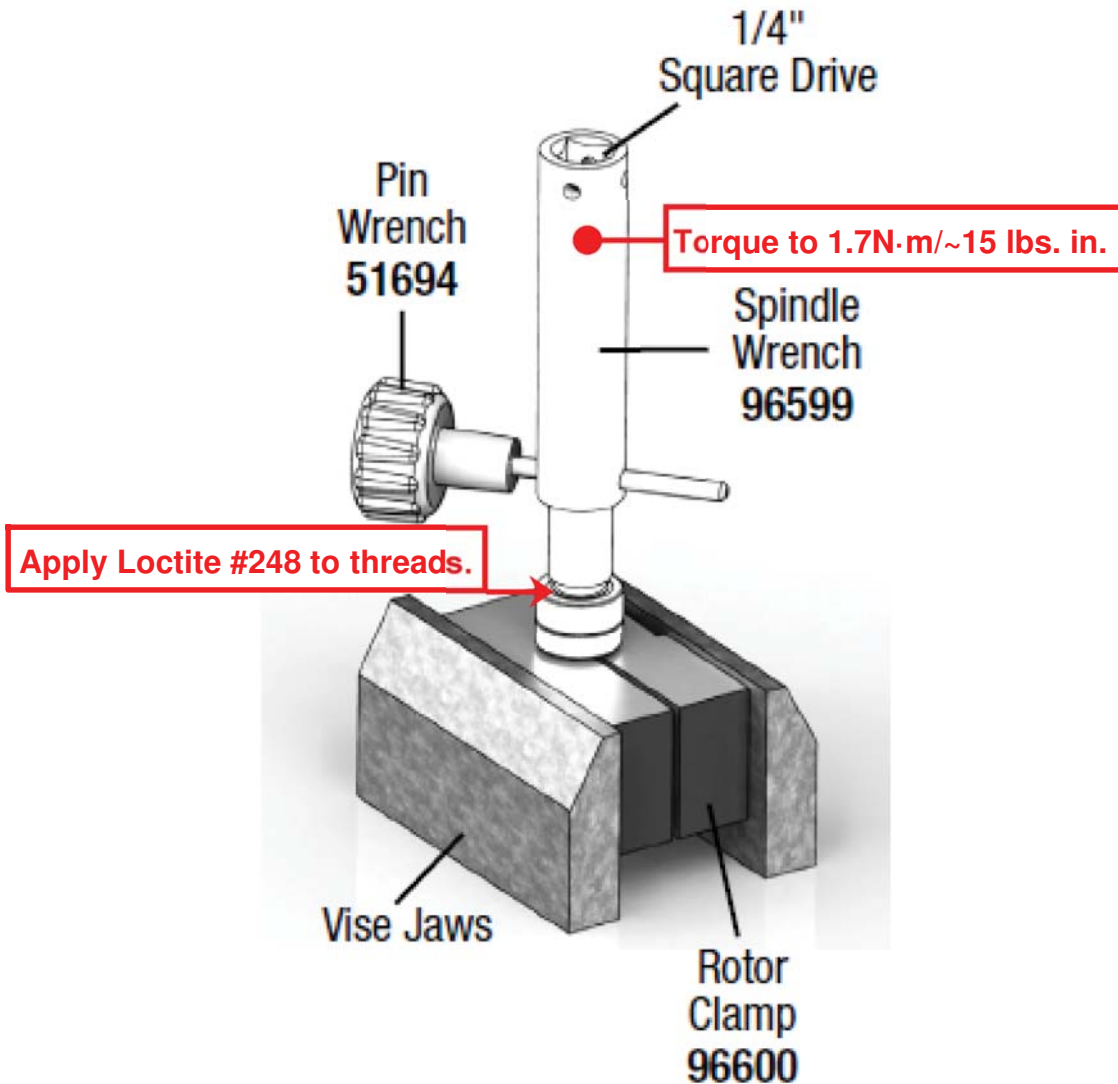

3. After properly shimming, place **55398** Rotor with **55397** Spacer, **55396** Front Bearing Plate, shims and **55395** Bearing into **96600** Rotor Clamp.
 - Tighten Rotor Clamp in vise.
 - Apply Loctite #248 to rotor threads and install **55392** Spindle.
 - Place **96599** Spindle Wrench over spindle and insert **51694** Pin Wrench.
 - Use 1/4" drive, torque wrench to tighten spindle. Torque to 1.7N·m/~15 lbs. in.

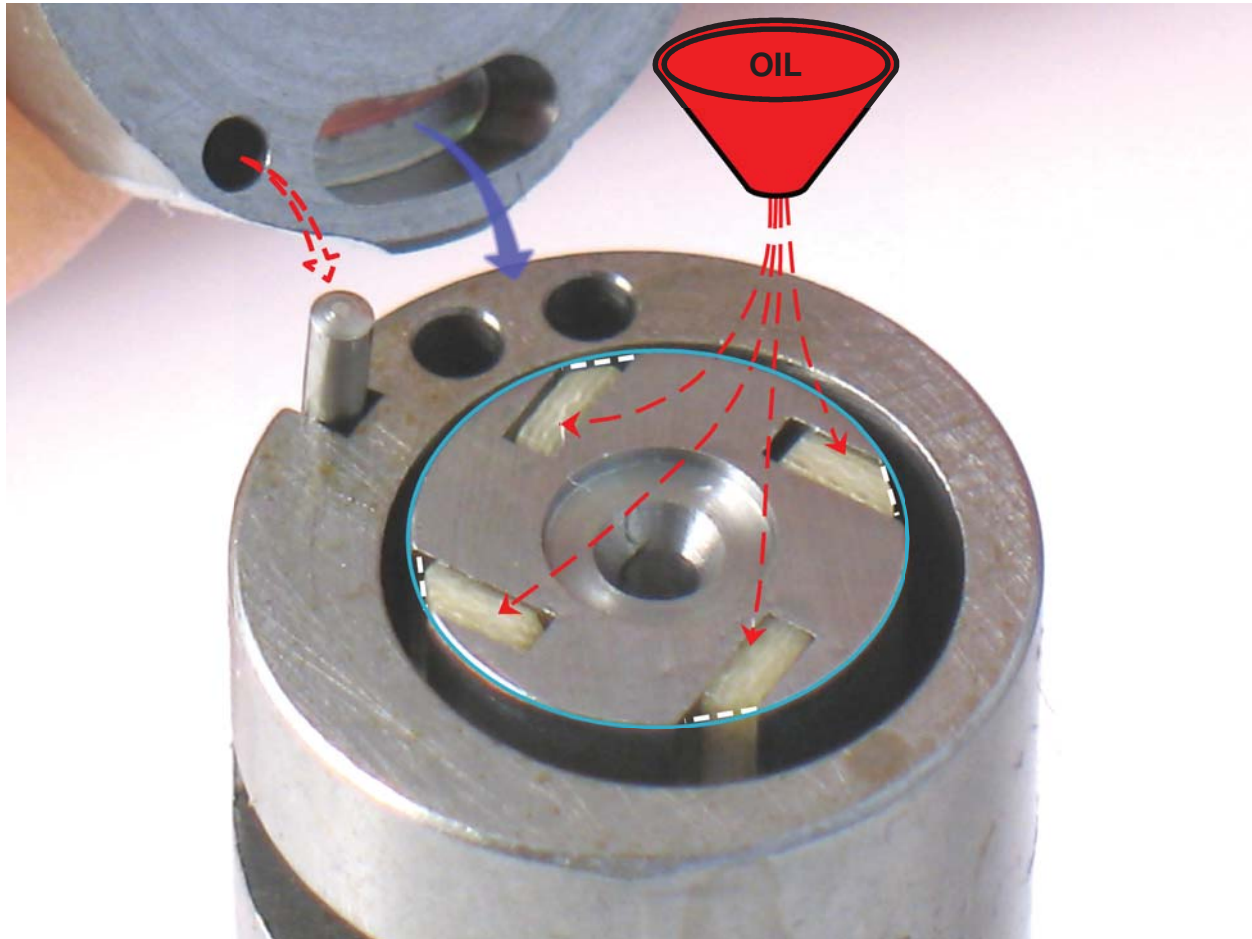

4. Install **55400** Cylinder with **96593** Pin, and air inlet, lined-up with holes in **55401** Rear Plate.

Notice: Oil **55404** Vanes. Use **95842** Dynabrade Air Lube, or equivalent.

- Install beveled-edge of vane to fit outside diameter of rotor.

Visit Our Website: www.dynabrade.com

Email: customer.service@dynabrade.com

DYNABRADE, INC. • DYNABRADE INTERNATIONAL
8989 Sheridan Drive, Clarence, New York 14031-1490 USA
Telephone: (716) 631-0100 • Fax: 716-631-2073 • Int'l Fax: 716-631-2524

DYNABRADE DO BRASIL
Rua Oneda, 632, Sao Bernardo do Campo • SP – CEP 09895-280
Telephone: 55-11-4390-0133 • Fax: 55-11-4399-1067

DYNABRADE EUROPE S.à.r.l.
Zone Artisanale, L-5485 Wormeldange—Haut, Luxembourg
Telephone: +352 768 494 1 • Fax: +352 768 495

DYNABRADE INDIA ABRASIVE POWER TOOLS Pvt Ltd.
EL-54, TTC Industrial Area, M.I.D.C. Mahape, Electronic Zone, Navi Mumbai - 400705
Maharashtra, India • Telephone: +91 22 2763 2226 • Fax: +91 22 2763 2228



5. Use Loctite #7649 Primer on threads at front and rear of housing. Also prime bearing diameter on the inside of housing.

Visit Our Website: www.dynabrade.com

Email: customer.service@dynabrade.com

DYNABRADE, INC. • DYNABRADE INTERNATIONAL
8989 Sheridan Drive, Clarence, New York 14031-1490 USA
Telephone: (716) 631-0100 • Fax: 716-631-2073 • Int'l Fax: 716-631-2524

DYNABRADE DO BRASIL
Rua Oneda, 632, Sao Bernardo do Campo • SP – CEP 09895-280
Telephone: 55-11-4390-0133 • Fax: 55-11-4399-1067

DYNABRADE EUROPE S.à.r.l.
Zone Artisanale, L-5485 Wormeldange—Haut, Luxembourg
Telephone: +352 768 494 1 • Fax: +352 768 495

DYNABRADE INDIA ABRASIVE POWER TOOLS Pvt Ltd.
EL-54, TTC Industrial Area, M.I.D.C. Mahape, Electronic Zone, Navi Mumbai - 400705
Maharashtra, India • Telephone: +91 22 2763 2226 • Fax: +91 22 2763 2228

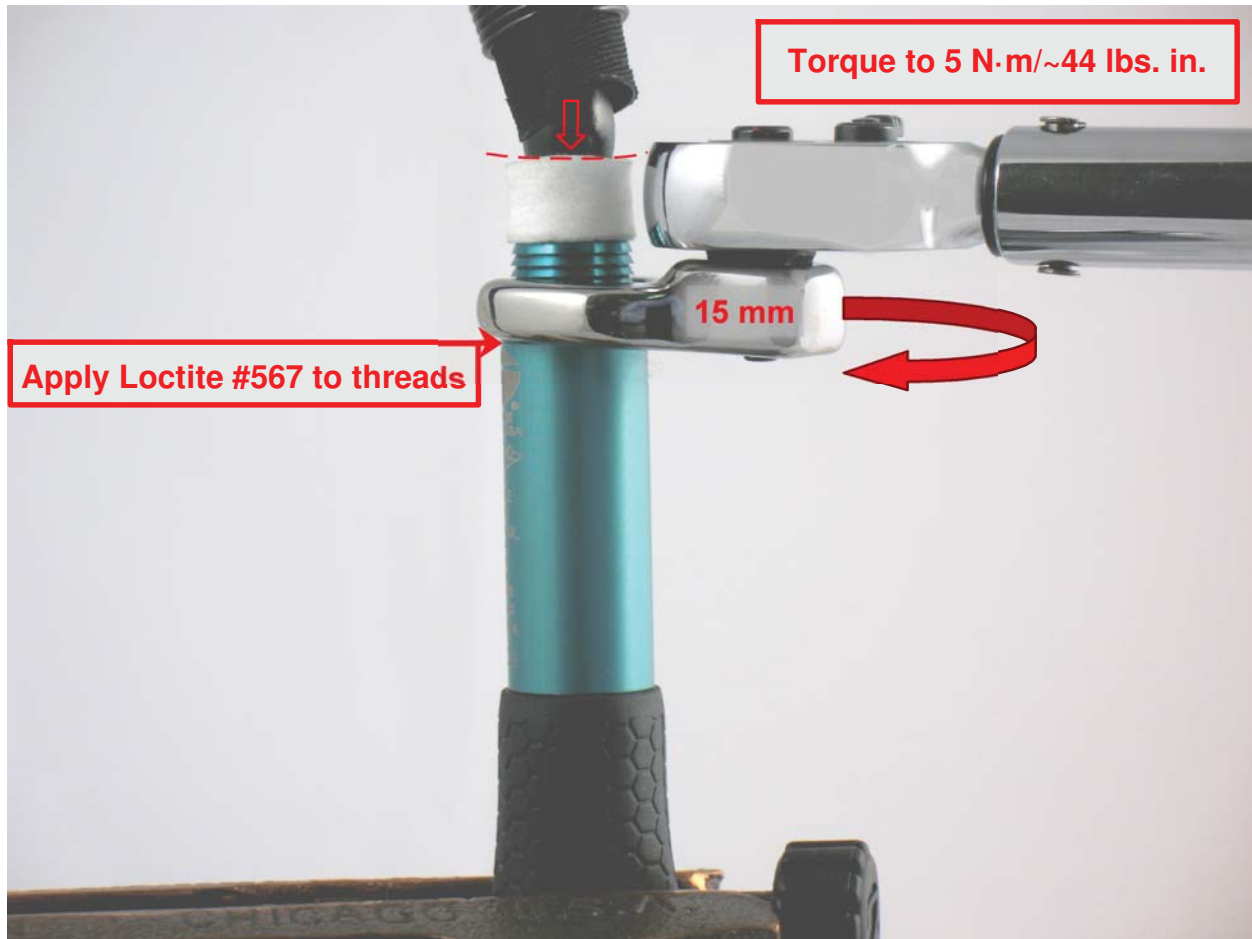

6. Install motor assembly along with **55402** Valve Seat, **55418** Muffler and **55419** Manifold Stem into housing.
 - Insert **51694** Pin Wrench through housing and spindle.
 - Fasten housing in vise with aluminum or bronze jaws, with **55419** Manifold Stem pointing up.
 - Apply Loctite #567 to threads of **55405** Valve Lock.
 - Use a 15 mm crowfoot wrench to fasten valve lock onto housing. Turn clockwise. Torque to 5 N·m/~44 lbs. in.
 - Install second **55418** Muffler onto manifold stem.
 - Install air hose with overhose and overhose clamp onto barbed end of manifold stem. **NOTICE:** Push air hose against **55418** Muffler to compress slightly.



7. Remove housing from vise.

- Carefully, invert tool assembly and fasten in vise with spindle pointing up.
- Install **55394** Wave Spring and **55416** Spacer.
- Apply a small amount of Loctite #290 to the outside diameter of **51544** Bearing.
- Install **51544** Bearing.

Visit Our Website: www.dynabrade.com

Email: customer.service@dynabrade.com

DYNABRADE, INC. • DYNABRADE INTERNATIONAL
8989 Sheridan Drive, Clarence, New York 14031-1490 USA
Telephone: (716) 631-0100 • Fax: 716-631-2073 • Int'l Fax: 716-631-2524

DYNABRADE DO BRASIL
Rua Oneda, 632, Sao Bernardo do Campo • SP – CEP 09895-280
Telephone: 55-11-4390-0133 • Fax: 55-11-4399-1067

DYNABRADE EUROPE S.à.r.l.
Zone Artisanale, L-5485 Wormeldange—Haut, Luxembourg
Telephone: +352 768 494 1 • Fax: +352 768 495

DYNABRADE INDIA ABRASIVE POWER TOOLS Pvt Ltd.
EL-54, TTC Industrial Area, M.I.D.C. Mahape, Electronic Zone, Navi Mumbai - 400705
Maharashtra, India • Telephone: +91 22 2763 2226 • Fax: +91 22 2763 2228



8. Install **94984** Debris Eliminator with larger diameter against bearing.
 - Use **96479** Retainer Wrench to install **51548** Retainer.
Torque to 2 N·m/~17 lbs. in.



9. Apply a small amount Loctite #567 to threads of **55390** Collet Guard.

Visit Our Website: www.dynabrade.com

Email: customer.service@dynabrade.com

DYNABRADE, INC. • DYNABRADE INTERNATIONAL
8989 Sheridan Drive, Clarence, New York 14031-1490 USA
Telephone: (716) 631-0100 • Fax: 716-631-2073 • Int'l Fax: 716-631-2524

DYNABRADE DO BRASIL
Rua Oneda, 632, Sao Bernardo do Campo • SP – CEP 09895-280
Telephone: 55-11-4390-0133 • Fax: 55-11-4399-1067

DYNABRADE EUROPE S.à.r.l.
Zone Artisanale, L-5485 Wormeldange—Haut, Luxembourg
Telephone: +352 768 494 1 • Fax: +352 768 495

DYNABRADE INDIA ABRASIVE POWER TOOLS Pvt Ltd.
EL-54, TTC Industrial Area, M.I.D.C. Mahape, Electronic Zone, Navi Mumbai - 400705
Maharashtra, India • Telephone: +91 22 2763 2226 • Fax: +91 22 2763 2228

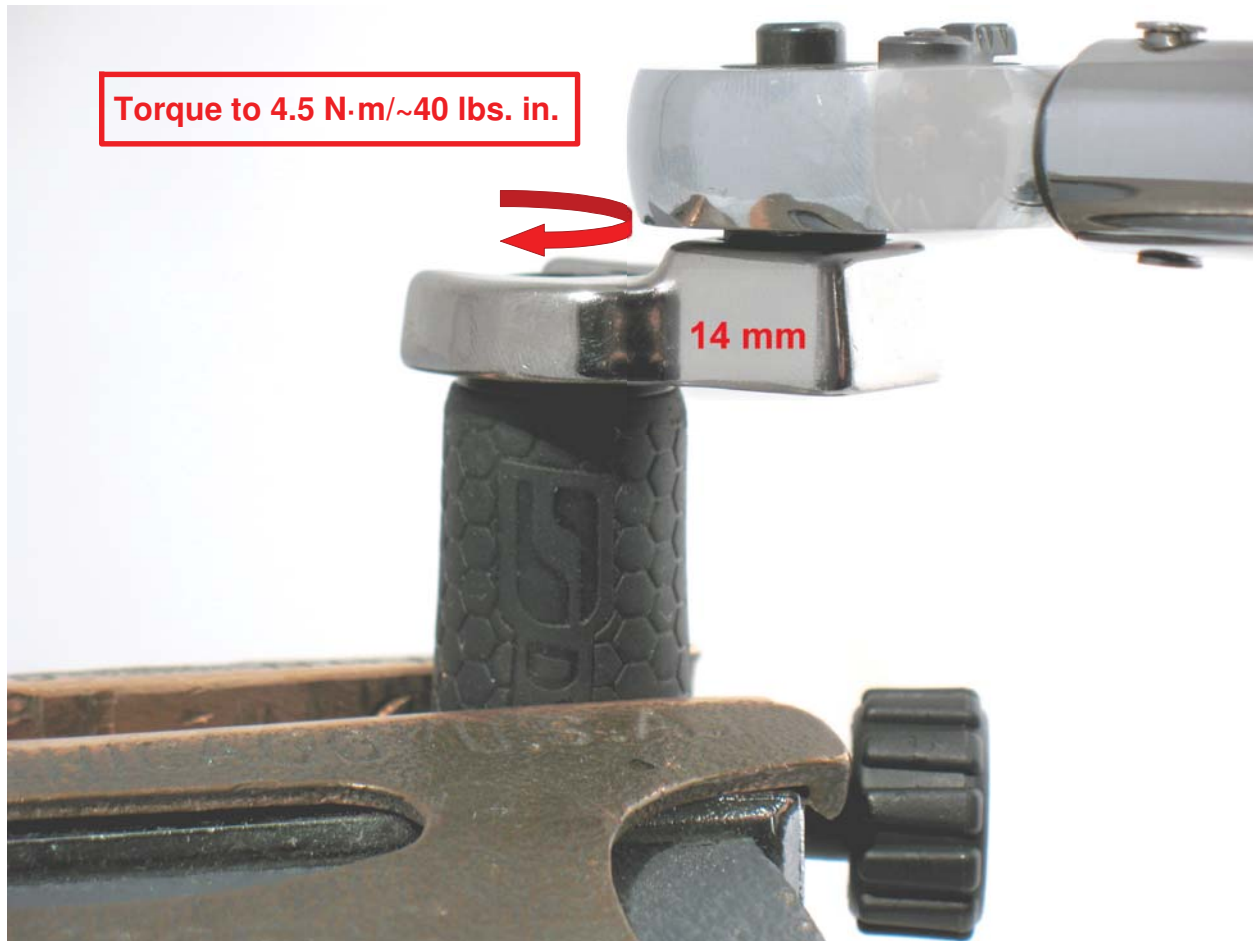

10. Use a 14 mm crowfoot and torque wrench to install collet guard.
Torque to 4.5 N·m/~40 lbs. in.

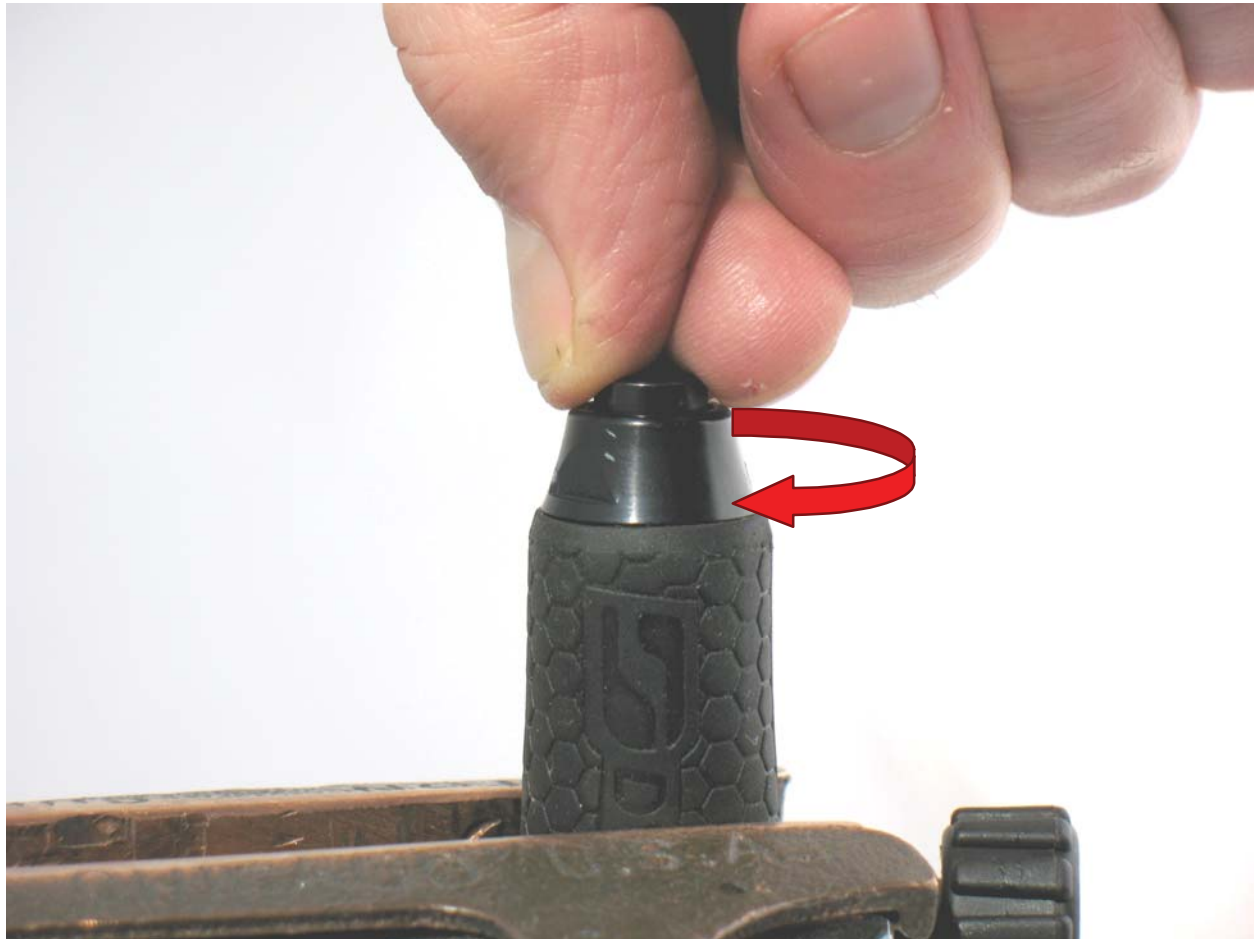

11. Install collet insert and **51657** Collet Cap. **NOTICE:** Do not over tighten collet.

Use tool parts page or manual to identify valve parts, and order of assembly.

Important: Before checking RPM, allow Loctite Threadlockers and Retaining Compounds to cure/fixture for 30 minutes.

- Supply **90 psig. (6.2 Bar)** maximum operating air pressure at air inlet of tool.
- Use tachometer to check maximum operating speed without an accessory in collet.

Assembly completed.

Visit Our Website: www.dynabrade.com

Email: customer.service@dynabrade.com

DYNABRADE, INC. • DYNABRADE INTERNATIONAL
8989 Sheridan Drive, Clarence, New York 14031-1490 USA
Telephone: (716) 631-0100 • Fax: 716-631-2073 • Int'l Fax: 716-631-2524

DYNABRADE DO BRASIL
Rua Oneda, 632, Sao Bernardo do Campo • SP – CEP 09895-280
Telephone: 55-11-4390-0133 • Fax: 55-11-4399-1067

DYNABRADE EUROPE S.à.r.l.
Zone Artisanale, L-5485 Wormeldange—Haut, Luxembourg
Telephone: +352 768 494 1 • Fax: +352 768 495

DYNABRADE INDIA ABRASIVE POWER TOOLS Pvt Ltd.
EL-54, TTC Industrial Area, M.I.D.C. Mahape, Electronic Zone, Navi Mumbai - 400705
Maharashtra, India • Telephone: +91 22 2763 2226 • Fax: +91 22 2763 2228